

# CT Operated R Type Overload Relay Installation & Fitting Instructions

## INSTALLATION

The current transformer (CT) should be mounted firmly on a flat surface (See Fig. 1). When the overload is attached to the C.T. the unit must be mounted in the correct attitude i.e. on a vertical surface with terminal markings readable from the front.

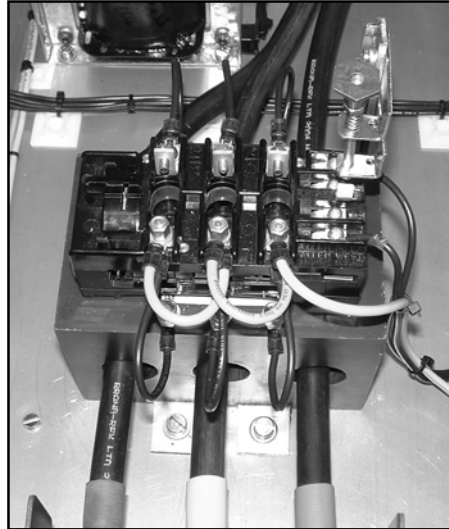

Fig. 1

The C.T. is provided with overload fixing screws and primary bar connecting bolts where applicable. There is also a self adhesive calibration label included for fitting to the 'R' Overload. This should be fitted over the adjusting lever on the left of the overload. The high, medium and low values of Motor Full Load Current may be marked onto either or both of the labels on the overload/C.T., the relevant values being selected from the charts overleaf. The current ranges will depend upon the heater selected. Please note that only heaters listed should be used in conjunction with the current transformers. See overload instruction sheet for heater installation procedure.

Secondary connections should be made between C.T. secondary terminals and overload terminals using 2.5m M2 cable (see Fig. 2). A connection kit AS 4050073 is available for this purpose.

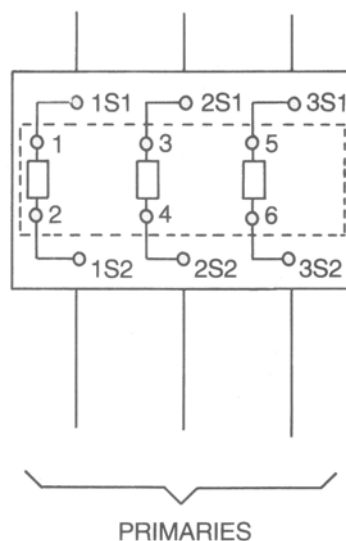

Fig. 2

# CT Operated R Type Overload Relay Installation & Fitting Instructions

## Selection Data

| Motor FL Amps<br>Line Connected |     |     | Motor FL Amps<br>Phase Connected |      |      | Overload<br>Heater | Current Transformer<br>Reference                          | Turns<br>Ratio |
|---------------------------------|-----|-----|----------------------------------|------|------|--------------------|---|----------------|
| L                               | M   | H   | L                                | M    | H    |                    |   |                |
| 61                              | 67  | 73  | 105                              | 116  | 126  | YA                 | CTR010015A<br>supplied with 3 holes<br>for primary cables | 1 - 15         |
| 72                              | 80  | 87  | 124                              | 137  | 150  | YB                 |   |                |
| 88                              | 97  | 106 | 152                              | 168  | 183  | YC                 |   |                |
| 106                             | 116 | 126 | 183                              | 201  | 218  | YD                 |   |                |
| 126                             | 138 | 150 | 218                              | 239  | 259  | YE                 |   |                |
| 150                             | 165 | 180 | 259                              | 285  | 311  | ZF                 |   |                |
| -                               | -   | -   | 246                              | 271  | 295  | YA                 | CTB010035A<br>supplied with 3 bar<br>primary connections  | 1 -35          |
| 168                             | 186 | 203 | 290                              | 321  | 351  | YB                 |   |                |
| 206                             | 227 | 248 | 356                              | 393  | 429  | YC                 |   |                |
| 245                             | 270 | 294 | 424                              | 466  | 508  | YD                 |   |                |
| 294                             | 322 | 350 | 508                              | 557  | 605  | YE                 |   |                |
| 350                             | 385 | 420 | 605                              | 666  | 726  | ZF                 |   |                |
| 345                             | 374 | 402 | 597                              | 646  | 695  | YB                 | CTB010065A<br>supplied with 3 bar<br>primary connections  | 1 -65          |
| 402                             | 441 | 480 | 695                              | 763  | 830  | YC                 |   |                |
| 480                             | 513 | 546 | 830                              | 887  | 944  | YD                 |   |                |
| 546                             | 619 | 692 | 944                              | 1071 | 1197 | YE                 |   |                |
| 692                             | 762 | 832 | 1197                             | 1318 | 1439 | ZF                 |   |                |

## HEALTH AND SAFETY AT WORK ETC, ACT 1974 STATEMENT TO PURCHASERS AND PROSPECTIVE PURCHASERS

Section 6 of this Act provides that manufacturers, designers, importers or suppliers of articles for use at work have a duty to ensure, so far as is reasonably practicable, that the articles will be safe and without risk to health when properly used. An article is not regarded as being 'properly used' if it is used without regard to any relevant information or advice relating to its use made available by the manufacturer, designer, importer or supplier.

Information on the design, construction and installation of our products to ensure that so far as is reasonably practicable they are safe and without risk to health when properly used may be found in:

- Relevant British Standards Specifications and Codes of Practice.
- Regulations for Electrical Installations (published by the Institution of Electrical Engineers),
- Catalogues and product leaflets of the Company.
- Or may be obtained by specific requests to the Company.

**It is important that the products concerned should be installed, commissioned and maintained by, or under the supervision of, competent persons in accordance with good engineering practice and:**

- IEE Regulations for Electrical Installations.
- Codes of Practice.
- Statutory requirements.
- Any instructions specifically advised by the Company and, where appropriate, with particular reference to information marked on the product.

In accordance with the provisions of the Act, you are therefore requested to take such steps as are necessary to ensure that any appropriate information relevant to our products is made available by you to anyone concerned.

**These notes assume throughout that the product is disconnected from the supply. It is essential that this is done before any work is carried out.**